

FORM FOR THE REGISTRATION OF FITTING DESIGNS

NEW BRUNSWICK
NUNAVUT

NOVA SCOTIA
YUKON

PRINCE EDWARD ISLAND
NORTHWEST TERRITORIES

NEWFOUNDLAND AND LABRADOR

MANUFACTURERS NAME: Swagelok Company	
MANUFACTURERS ADDRESS: 29500 Solon Road, Solon, Ohio 44139 USA	
PLANT LOCATIONS: Headquarters: 29500 Solon Road, Solon, Ohio 44139 USA (See Attachment A)	
CATEGORY OF FITTINGS TO BE REGISTERED. CIRCLE ONE CATEGORY ONLY A Pipe fittings, including couplings, tees, elbows, Ys, plugs, unions, pipe caps, or reducers B Flanges: all flanges <input checked="" type="radio"/> C Valves: all line valves D Expansion joints, flexible connections, and hose assemblies: all types E Strainers, filters, separators, and steam traps F Measuring devices, including pressure gauges, level gauges, sight glasses, levels, or pressure transmitters G Certified capacity-rated pressure relief devices acceptable as primary over pressure protection on boilers, pressure vessels, piping and fusible plugs H Pressure retaining components that do not fall into one of the above categories N Nuclear components: Class 1 <input type="checkbox"/> Class 2 <input type="checkbox"/> Class 3 <input type="checkbox"/> , (Meeting AECB or ASME requirements)	TITLE OF THE STANDARD OF CONSTRUCTION ASME B31.3 Chapter IX as an unlisted component
SHOW MANUFACTURERS NAME, TRADEMARK, OR LOGO AS IT WILL APPEAR ON THE PRODUCT 	TYPE OF CONSTRUCTION FORGED <input type="checkbox"/> WELDED <input type="checkbox"/> WROUGHT <input type="checkbox"/> CAST <input type="checkbox"/> OTHER <input checked="" type="checkbox"/> DESCRIBE OTHER: Bar
LIST OF SUPPORTING DOCUMENTATION AND IDENTIFICATION OF THE ACTUAL ITEMS TO BE REGISTERED: ISO 9001:2015 Certificate, Attachment A, Attachment B, Catalog Information and other Support Documents	

DECLARATION:

I Joel Feldman, Vice President, Engineering (see note 3) employed by Swagelok Company and being the person having full authority and responsibility for the quality of the end product do solemnly declare that the information contained in this form is true and to the best of my knowledge represents the product for which registration is sought. The dimensions, materials of construction, pressure temperature ratings, and identification markings are in accordance with the herein named standards. I further declare that the manufacture of these fittings is regulated by a Quality Control Program which extends to each plant where fabrication occurs in whole or in part and has been verified by BSI as being suitable for that purpose and I make this solemn declaration conscientiously believing it to be true, and knowing that it is of the same force and effect as if made under oath.

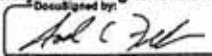
Signature of Declarer:  3/2/2022 | 8:53 AM EST

Declared before me at Unable to get a notary
This _____ day of AD
Commissioner of Oaths signature or seal due to
or Notary Public: (sign) COVID-19 situation
(Affix Official seal to the right)

USE THIS SPACE FOR THE
OFFICIAL SEAL

This space for Regulatory Authority use
This registration must be revalidated after ten (10) years from the date of acceptance.

CRN: QC15674.5Y Rev1
FID#: 1214

Notes:
1. All fittings shall be registered in the name of the Manufacturer.
2. Each category shall be supported with two Statutory Declaration forms and one copy of supporting documentation.
3. The declaration shall be made by the person having full authority and responsibility for the quality of the end product.
4. Quality control programs shall be resubmitted for validation at a maximum interval of five (5) years.



Attachment B. Scope of CRN Registration for Swagelok FKB Series Medium Pressure Ball Valves (Category C)

This document represents the scope of the FKB Series Medium Pressure Ball Valves, covered by this submission for CRN approval. These products were designed and evaluated in accordance with ASME B31.3-2020 Chapter IX for unlisted components.

Summary Table

Product Series	Main Pressure Bearing Component	Main Pressure Bearing Material (Standard)	Port Connections and Sizes	Maximum Rated Pressure (psig)		Design Code of Construction
				At 0 to 100°F	At maximum temperature	
6FKB (2-way) and (3-way)	Body	316 SS (ASTM A479)	Medium Pressure Tube Fitting 1/4", 3/8", 1/2" Female NPT 1/4", 3/8", 1/2"	15,000	15,000 at 250°F	ASME B31.3, Chapter IX (Unlisted Components)
8FKB (2-way) and (3-way)	Body	316 SS (ASTM A479)	Medium Pressure Tube Fitting 1/2", 9/16" Female NPT 1/2"	15,000	15,000 at 250°F	
12FKB (2-way)	Body	316 SS (ASTM A479)	Medium Pressure Tube Fitting 3/4"	15,000	15,000 at 250°F	
			Female NPT 3/4"	10,000	10,000 at 250°F	

Product Illustration

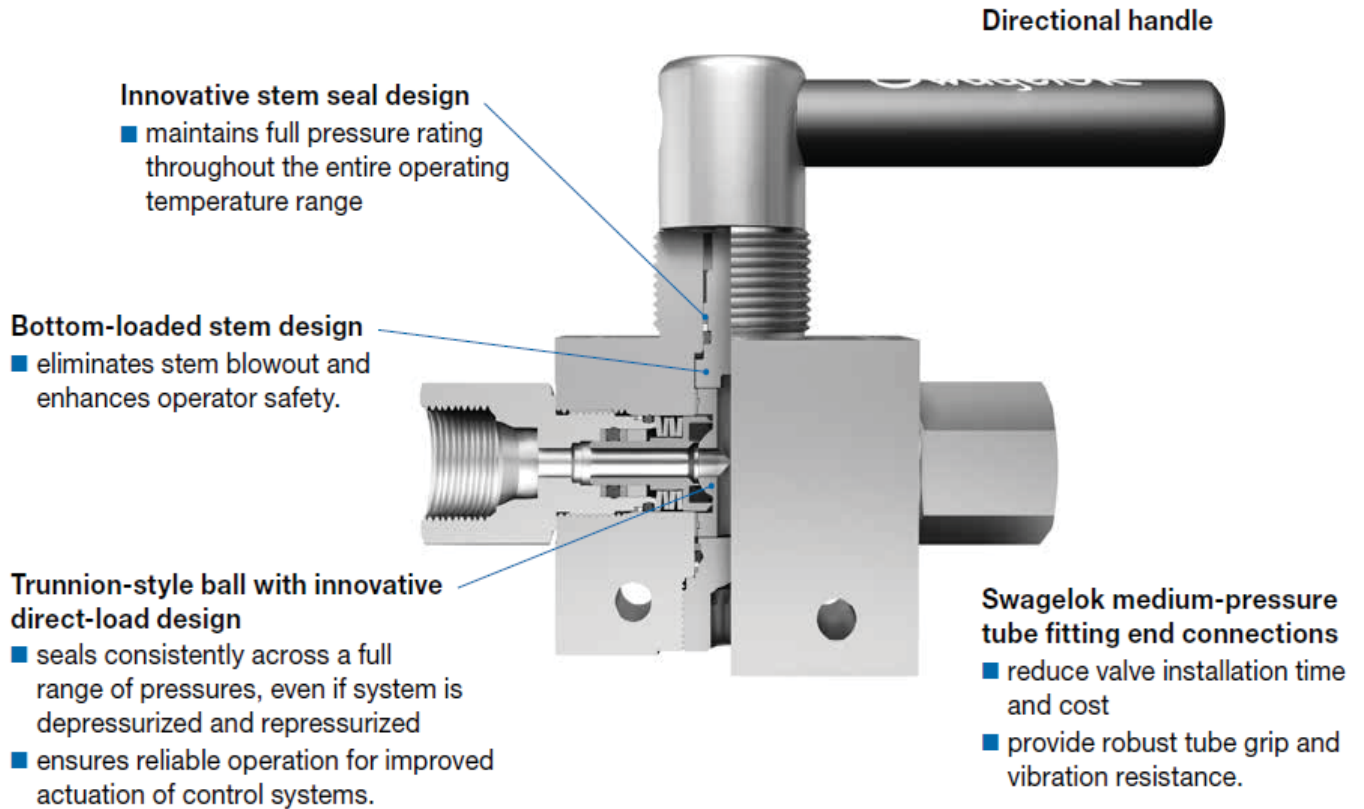

Configurations

Valves are available in 2-way and 3-way pattern, and either manually or pneumatically actuated.

2-Way (On-Off) Valve

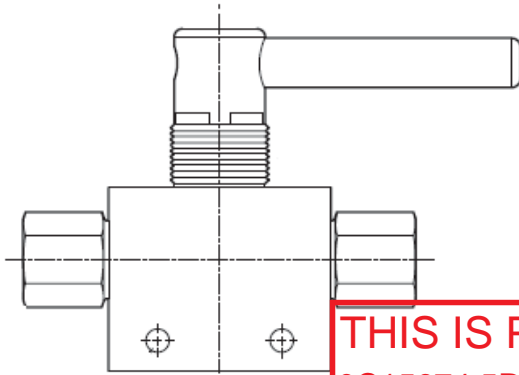

3-Way (Switching) Valve

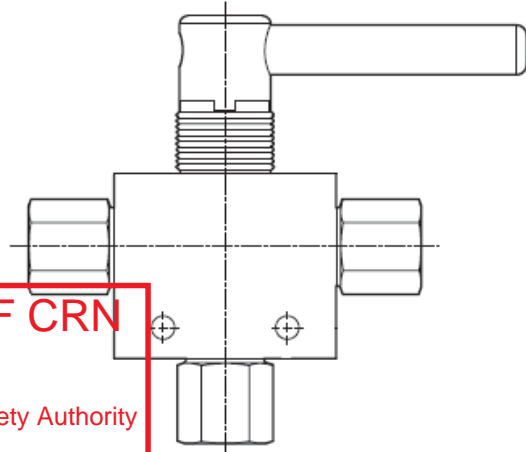

**THIS IS PART OF CRN
0C15674.5R1**

Technical Standards and Safety Authority
Boilers and Pressure Vessels Safety
Program

Typical Product Characteristics:

Some of the product options listed below affect pressure and/or temperature ratings shown in the above Summary Table, but in all cases the ratings are less than those shown in the table. All of the following options are within the scope of this approval.

O-ring Stem Seal Options

HNBR Nitrile
Perfluorocarbon FFKM

Additional options and non-pressure boundary alterations that do not affect pressure-temperature ratings may be made available within the scope of this registration. Examples of these would include handle options, actuator options, etc.

Quality System

The Swagelok Company quality system complies with the requirements of ISO 9001:2015. The Swagelok Company maintains BSI Certificate of Registration Number FM 01729, which applies to all locations listed on the Certificate.

References

The product catalog below does not represent the full scope of the registration but rather details some of the most common options.

- Medium- and High-Pressure Fittings, Tubing, Valves, and Accessories Product Catalog MS-02-472 Rev R

Attachment A. Swagelok Manufacturing Locations

This document lists the Swagelok locations where end item or component level manufacturing activities take place.

THIS IS PART OF CRN
0C15674.5R1

Technical Standards and Safety Authority
Boilers and Pressure Vessels Safety Program

Swagelok Company 29500 Solon Road Solon, Ohio 44139 USA	Swagelok Company (Falon 1) 348 Bishop Road Highland Heights, Ohio 44143 USA
Swagelok Company (Highland) 318 Bishop Road Highland Heights, Ohio 44143 USA	Swagelok Company (Falon 2) 358 Bishop Road Highland Heights, Ohio 44143 USA
Swagelok Company (OFC) 29495 F.A. Lennon Drive Solon, Ohio 44139 USA	Swagelok Company (HPF) 6050 Cochran Road Solon, Ohio 44139 USA
Swagelok Company (Atlantic) 26651 Curtiss Wright Parkway Willoughby Hills, Ohio 44092 USA	Swagelok Company (Snow Metal) 6060 Cochran Road Solon, Ohio 44139 USA
Swagelok Company (Micro) 26653 Curtiss Wright Parkway Willoughby Hills, Ohio 44092 USA	Swagelok Company (Alfred) 29500 Ambina Drive Solon, Ohio 44139
Swagelok Hose Services Company (SHSC) 29900 Solon Industrial Parkway Solon, Ohio 44139	Swagelok Company (Strongsville) 15400 Foltz Road Strongsville, Ohio 44119
Swagelok (China) Fluid System Technologies Ltd. Changshu Export Process Zone Changshu Economic Development Zone Changshu, Jiangshu 215513 China	Swagelok Limited Ballafletcher Road Tromode IM4 4RA Isle of Man